

**A Concept for Sled Testing Minuteman III
Guidance Systems**

**Hossny El-Sherief,
Dave Knight, Dan Simon, and Myron Teeter**

**TRW Ballistic Missiles Division
Systems Integration Group
P.O. Box 1310
San Bernardino, CA 92402-1310**

Approved for Public Release; distribution is unlimited.

ABSTRACT

Rocket sled testing has proven to be a useful tool for evaluating the functional performance and accuracy of inertial navigation systems. Sled testing can be used to evaluate the performance of new prototype system designs as well as the performance degradation or design enhancement of mature systems.

This paper describes the status of a conceptual study that is underway for sled testing the Minuteman III, NS-20 Guidance System. Although the NS-20 has an extensive in-flight and ground test history, rocket sled testing has not been conducted on this system. In this paper, the basic advantages and limitations of sled testing the NS-20 system are compared to other forms of ground tests and flight tests. Specific benefits of sled testing this mature guidance system are identified. Potential sled test show stoppers, guidance error observability, the sled test vibration environment, and the necessary sled test equipment and software modifications are discussed.

I. INTRODUCTION

Rocket sled testing has proven to be a useful, non-destructive test for evaluating inertial navigation systems in a highly dynamic environment [Bunce, Nielson]. Figure 1 depicts a typical sled test space-time system, and Figure 2 shows the tracksite configuration. Although the Minuteman III guidance system (NS-20) first became operational over 22 years ago and has an extensive in-flight and ground test history, rocket sled testing has not been conducted on this system. This contrasts with many other ICBM guidance systems which have undergone extensive sled testing.

The predecessor to the NS-20, the Minuteman II NS-17 Guidance System, underwent a total of 21 sled tests in 1973 and 1974. These tests were conducted to augment a reduction in Minuteman II flight tests. The Peacekeeper Advanced Inertial Reference Sphere (AIRS) guidance system has undergone a total of 72 sled test runs dating back to 1977 [Cuevas], including a series of nine test runs in 1993. The AIRS was tested for a variety of reasons, although the common objective was to evaluate alignment accuracy and overall system performance. AIRS sled tests are currently scheduled through 1999. The AIRS guidance system also underwent 12 sled tests as part of the Rail Garrison program in 1989 and 1991 [Cuevas].

The two candidate designs for the Small Intercontinental Ballistic Missile guidance systems, the Alternate Inertial Navigation Systems (AINS), were sled tested as part of their design evaluation and part of the procedure to select from competing

designs. The two versions of the Advanced Inertial Measurement Unit (AIMU) brassboard units (high acceleration reentry guidance systems) also underwent sled tests as part of the design assessment and to compare competing designs.

Sled tests are currently planned for the new Advanced Inertial Measurement System (AIMS) in early 1994 to compare competing designs [Hand].

Given the significant benefits derived from sled tests conducted on many other guidance systems, could sled testing have value for the mature NS-20 guidance system? This paper discusses a conceptual study that has been performed to answer that question. The possibility of using sled testing as a method to detect age-related degradation in accuracy, reliability and functional performance is discussed. Augmentation of the current NS-20 flight test program through sled testing is addressed. Specifics of an NS-20 sled test program are discussed, including the potential show stoppers, and the equipment needed for the test facility and the NS-20 guidance system. The software needed for sled testing is described, and the observability of the guidance error terms in a sled test are discussed. Sled testing of the NS-20 is compared to other tests, e.g. flight tests, vibration tests, and centrifuge tests.

II. POTENTIAL SHOW STOPPERS

At the inception of this study, three areas were identified as potential show stoppers—that is, concerns that could be serious enough to prevent a worthwhile NS-20 sled test program. The first was a concern that the sled test environment would seriously damage the NS-20 gyrocompass assembly (GCA) or degrade its accuracy. The second was the availability of guidance system support equipment suitable for sled testing, and the third was the lack of spare memory in the NS-20 Guidance System computer.

II-A. NS-20 GYROCOMPASS ASSEMBLY

The concern regarding the GCA's ability to withstand the sled test environment was based upon the knowledge that the GCA is used only for pre-flight azimuth alignment. It has no purpose after launch. Since it does not matter if it is damaged in flight (it will obviously never be used again), its ability to withstand the flight environment (or simulated flight environment in sled tests) without damage or degradation was suspect. The cost of repairing or replacing the GCA after sled test induced damage would make sled testing unacceptable. Damage to the GCA would also compromise a major sled test benefit - repeated tests on the same guidance set.

The Minuteman II NS-17 Guidance System sled test program answered this concern. At the time this study was initiated, it was not known that NS-17 systems had been sled tested. This discovery and subsequent review of the test documentation revealed that multiple sled test runs had been conducted on four NS-17 systems. Extensive functional and performance data were taken before and after each run. Analysis revealed no evidence of GCA damage or accuracy degradation. Although the NS-17 and NS-20 GCAs differ slightly, these differences are not in areas that would affect the NS-20 GCA's ability to withstand the sled test environment. Consequently, it can be stated with confidence that sled testing will not damage or degrade the accuracy of the NS-20 GCA.

II-B. GUIDANCE SYSTEM SUPPORT EQUIPMENT

The second concern was the possible lack of suitable NS-20 Guidance System sled test support equipment. This concern was based upon the prospect that the NS-20 Factory Test Equipment (FTE) would have been required for NS-20 sled tests, just as the NS-17 FTE had been the guidance support equipment for the NS-17 sled tests. Concerns about the NS-20 FTE included its age (over 20 years old), its obsolescence (based on old IBM 1800 computer technology), its questionable reliability, and the fact that it is large and difficult to transport, set up and debug. On top of these concerns, there was uncertainty regarding the availability of the NS-20 FTE. Fortunately, alternatives for guidance system support equipment fulfilling NS-20 sled test requirements have been identified, thus eliminating this concern. The comparisons between alternatives are discussed later in this paper.

II-C. GUIDANCE SYSTEM COMPUTER SPARE MEMORY

The third concern, extremely limited spare memory in the NS-20 computer, was also eliminated as a show stopper. It was thought that added instructions would be needed in the resident NS-20 Operational Ground Program (OGP) and Operational Flight Program (OFF) for the sled test functions. It was concluded that overwriting the OFF with a sled test program can solve the memory needs. Other potential solutions are also being investigated. It is concluded that this is not a show stopper, but it is a challenging area for an NS-20 sled test program. This subject is addressed in more detail later in this paper.

III. GUIDANCE ERROR OBSERVABILITY

This section discusses results of a covariance analysis which was conducted to determine the observability of guidance errors.

A Kalman filter has been implemented in a simulator program to estimate NS-20 guidance errors based on simulated sled test data. The start of the simulated sled track is located at 34 degrees latitude, and the track runs due north (although in reality the track runs 4 degrees off of true north). The x-platform axis of the NS-20 points along the sled track. Figure 3 shows the NS-20 geometry. The sled test software applies a constant torque to the NS-20 to maintain it in a locally level orientation (with respect to the launch point). One important result of this torquing is that acceleration-sensitive NS-20 errors are driven by real acceleration (with respect to inertial space) rather than by the acceleration which is sensed by the accelerometers (which includes acceleration due to gravity). The simulated sled acceleration lasts for 80 seconds, although the acceleration during the last 50 seconds or so is fairly low, as the sled is simply coasting to a stop. The acceleration varies between -5.6 and 6.7 g's, and the velocity reaches a maximum of 850 miles per hour. By the time the sled stops moving, it has travelled slightly over 4 miles. The sled test includes 60 seconds of pre-run and 60 seconds of post-run data collection sandwiched around the 80 seconds of hot-run data collection, for a total of 200 seconds of test time. The sled trajectory acceleration which was used is shown in Figure 4, and was obtained from an analytical approximation found in [Aiyawar].

The covariance part of the Kalman filter was propagated during the 200 seconds of the sled test at a 100 Hz rate to determine the increase of information that would result from a sled test. The state of the Kalman filter is composed of NS-20 errors [Rockwell]. Since the errors are assumed to be constant during the duration of the sled test, the state transition matrix of the linear system is the identity matrix and the process noise is zero. The measurement of the system is the difference between the NS-20-indicated velocity and the track-indicated velocity. The measurement matrix is therefore the sensitivity of the NS-20-indicated velocity to the NS-20 errors [McAllister]. The Kalman filter covariance is thus propagated as follows [Gelb]:

$$K_k = P_{k-1} H_k^T (H_k P_{k-1} H_k^T + R_k)^{-1}$$

$$P_k = (I - K_k H_k) P_{k-1}$$

where K is the Kalman filter gain, R is the covariance of the measurement noise, H is the measurement matrix, I is the identity matrix, and P is the covariance of the state estimate. The square roots of the diagonal entries of P are the standard deviations of the state estimates. Note that the actual state estimate does not need to be computed in order to compute the covariance matrix P.

The measurement noise values employed came from a PIGA noise mitigation method developed by Rockwell and currently used to

evaluate IMU performance during NS-20 vibration tests. In this method the precise time of each PIGA pulse is determined thereby reducing pulse quantization standard deviation from 0.0346 feet per second to noise that can be modelled by the equation

$$\sigma = \max (0.003, 0.0029 * g) \quad (\text{ft/sec}).$$

This equation means the standard deviation of the PIGA noise is the maximum of either 0.003 or 0.0029 times the absolute magnitude of sensed acceleration in g's. Similarly, by this equation, the noise can not be less than 0.003 feet per second.

The information gained about NS-20 error terms can be quantified by recovery ratios. The recovery ratio for an error state is the final standard deviation of the state estimate divided by the initial standard deviation, so a low recovery ratio corresponds to a better estimate and a greater increase in information. A recovery ratio less than approximately 0.5 generally indicates that a significant amount of new information has been gained about the error state under consideration.

Table 1 shows the NS-20 recovery ratios for one standard deviation magnitudes of the NS-20 error terms. It can be seen from Table 1 that nine NS-20 errors are recoverable from an NS-20 sled test if a slight latitude is extended in the 0.5 ratio criteria. Interpretation of this result, however, requires an understanding of which error terms are important contributors to impact miss. Observability of an error term that is insignificant to the NS-20 CEP is of no value; observability of errors that are major miss contributors, however, is crucial to the determination of whether or not sled tests can be used as a method to assess guidance system accuracy.

The NS-20 Error Model Document [Rockwell] identifies the major sources of impact miss to be:

- (1) Azimuth alignment error
- (2) Calibration error
- (3) Gyro g- and g²-sensitivities (primarily B and S coefficients);
- (4) PIGA scale factor errors
- (5) Accelerometer input axis misalignments due to flight vibration and shock; and
- (6) Deployment errors.

Table 1 - NS-20 Recovery Ratios

NS-20 Error	One-sigma Recovery Ratios
Initial Conditions	
Asimuth	0.17
West Alignment	0.23
North Alignment	0.53
Accelerometer	
x bias	0.54
y bias	0.72
z bias	0.72
x scale factor	0.31
y scale factor	0.82
z scale factor	0.82
x input g²	0.44
y input g²	0.83
z input g²	0.83
Gyro	
x bias	0.80
y bias	0.43
z bias	0.92
g-sensitive	
SB2	0.92
SA1	0.90
SB1	1.00
C2	0.82
C1	0.98
D2	1.00
D1	0.89
g² sensitive	
B2	0.52
B1	0.73
E2	1.00
E1	0.17
FB2	0.96
FA1	1.00
FB1	1.00

Clearly, item (6) cannot be monitored with sled testing.

Item (5) will be observable by comparison of calibration data before and after the sled test run.

When the analysis indicated some of the important error terms were not observable at one standard deviation, additional analyses were run with each of these unobservable errors increased to a three standard deviation magnitude one at a time.

Item (4), PIGA scale factor, is observable, at one sigma on the x PIGA and three sigma on the y and z PIGAS (both y and z ratios dropped to 0.43 at three sigma).

For item (3), the B2 error term is observable at one sigma and B1 becomes observable at three sigma (ratio 0.34). The S coefficients ratios (0.62 and 0.57 respectively) indicate they might become observable at slightly larger values.

Many of the elements of the calibration error, item (2), are due to misalignment between the alignment reference block and the flight instruments (PIGAS and G6 gyros). These errors manifest as azimuth alignment and level alignment errors, which have good observability in sled test.

Azimuth alignment, item (1), is readily observable even at one standard deviation.

IV. POTENTIAL BENEFITS OF CONDUCTING AN NS-20 SLED TEST PROGRAM

As mentioned in the Introduction, the purpose of this study is to determine if there is benefit to be gained by sled testing the mature NS-20 Guidance System. There is little incentive to conduct sled tests to improve accuracy and/or reliability since the NS-20 currently meets its requirements on both. It is postulated that NS-20 sled tests could be used, however, as a monitor to identify age-induced degradations in accuracy, functional performance, and/or reliability. As such, sled tests could augment the monitoring provided by the NS-20 flight test program which is currently limited to three flights per year after having been six flights a year for a considerable period. Problems could be detected and corrected as much as a year earlier than with flight tests alone.

For a sled test program to be a credible monitor for accuracy degradation of an aging system, however, the major flight errors must be excited by the sled test trajectory. The analysis

described in Section III was conducted to determine if this is the case. It was shown that with the exception of the RV deployment error, most of the major in-flight errors are observable in sled tests if a three standard deviation magnitude is permitted for some of the error terms. For an accuracy degradation monitor this would probably be acceptable. It thus appears that rocket sled testing would be an effective test method to monitor NS-20 accuracy degradation.

If it is decided to initiate an NS-20 sled test program, it is envisioned that this program might be patterned after the successful AIRS sled test program, where each year three test runs each have been conducted on three guidance systems. Conducting sled tests on three NS-20 guidance systems would thus double the sample size of guidance systems tested in a dynamic environment (combining sustained acceleration, vibration, and shock), compared to flight tests alone. The three runs per system provide insurance against being unduly influenced by a single anomalous test run; combining each systems' three test results would produce more representative performance than a single test.

The accuracy monitoring would be accomplished by comparing the total sled test guidance system error with the total guidance system error predicted by the NS-20 Error Budget. As long as the guidance system accuracy stayed within the one standard deviation boundaries predicted by the error budget, no further analysis would be performed. Test results exceeding the boundaries would be analyzed to determine their cause. Test results indicating a pattern of accuracy degradation with the passage of time, as might be expected with this aging system, would also be analyzed as to cause.

Functional performance would be monitored under a sled test program by reviewing functional signals for aberrant behavior. Reliability monitoring would be achieved by analyzing any guidance system failures.

V. SLED TESTING VERSUS OTHER TEST METHODS

There are several methods other than sled testing which can be used for testing a given guidance system. Some of these methods are flight testing, centrifuge testing, vibration testing, and subsystem/component testing. This section discusses the pros and cons of sled testing as compared to each of these alternatives.

V-A. SLED TESTS COMPARED TO FLIGHT TESTS

Minuteman III flight tests from Vandenberg Air Force Base (VAFB) are unquestionably more realistic approximations to an operational mission than are rocket sled tests. A test flight

trajectory is quite similar to an operational trajectory. The acceleration, vibration, and shock environments approximate those of operational launches.

Sled tests, however, offer the advantages that they cost much less than flight tests. In addition, the guidance system is not expended in a sled test so the same unit can be tested repeatedly to obtain multiple measurements which has many advantages. A test procedure can be modified and the test repeated on the same unit. Furthermore, calibration can be conducted before and after the sled run to precisely measure any changes. The sled track provides a very precise reference for accuracy evaluation. The guidance systems can be oriented to improve error term observability and changes can be readily made to obtain additional data. Although the rocket sled test is a significantly less realistic approximation of an actual operational Minuteman III mission than a VAFB flight test, it is the closest test to a flight test that can be done on the ground. It provides a unique combination of flight-like environments of sustained acceleration with some application of vibration and shock.

V-B. SLED TESTS COMPARED TO CENTRIFUGE TESTS

Centrifuge tests could also be used to investigate NS-20 performance [Peters2], but sled tests are the best ground test approximation to flight tests. The centrifuge rotational method of obtaining sustained g's departs significantly from an ICBM trajectory simulation with a greater time to maximize acceleration. As a consequence, centrifuge tests aggravate gyro drift errors that persist for a shorter time during the ICBM boost phase of a flight trajectory. This significantly complicates the use of centrifuge tests as a method of assessing guidance system performance. In addition, existing centrifuges which are capable of testing the NS-20 lack sufficient accuracy for performance assessment. This is due to such things as arm stretch and wobble, and the lack of precise position and velocity measurements for comparison to NS-20 measurements. Centrifuge tests are less costly than sled tests.

V-C. SLED TESTS COMPARED TO VIBRATION TESTS

Vibration tests can provide a closer approximation to the flight test vibration environment [Burnett,Peters1], but cannot produce the sled test linear acceleration which is key in assessing the response of the guidance accelerometer under simulated flight and the platform gimbal structures and gimbal servos performance under inertial loading. Sled test vibration levels vary from test to test, but these levels are on the same order of magnitude as flight levels. Vibration testing is much less costly, however, than sled testing, and requires less test time. As a consequence,

many more systems can be tested in a given time frame and for a given dollar cost.

V-D. SLED TESTS COMPARED TO SUBSYSTEM/COMPONENT TESTS

When comparing sled tests to guidance subsystem/component tests, sled testing has the advantage that the tests are on the entire guidance system in an environment that more realistically approximates the mission. Tests at levels lower than the full guidance system have the inherent risk that they may produce results not fully representative of the guidance system as a unit. In addition, tests on the full guidance system may help identify unmodelled or inadequately modelled error terms. These error terms may not be revealed in lower level testing, because either the environment cannot be duplicated, or the test procedure is not properly designed to excite the error terms (since their existence is either unknown or inadequately understood).

On the other hand, subsystem and component testing are much less expensive than sled testing. Subsystem/component tests also have greater versatility in that more components can be tested and larger sample sizes are easier to obtain.

Given the strengths and weaknesses of sled tests versus subsystem/component tests, the two test methods could be employed in conjunction. Subsystem/component tests could be used to analyze problems or anomalies found in sled tests.

VI. SLED TEST EQUIPMENT REQUIREMENTS AND SOFTWARE MODIFICATIONS

A major concern regarding the viability of NS-20 sled tests is the identification of available guidance support equipment (GSE) that can meet the sled test requirements with few or no modifications. If major modifications are required or new equipment has to be designed and built, the development time and cost will weigh heavily against the value of the test.

As mentioned earlier, the NS-17 sled test program had used the Factory Test Equipment (FTE). At the time of the NS-17 tests in 1973 and 1974, this FTE was fairly new and up-to-date. However, the NS-20 FTE is now relatively antiquated and is showing its age with unreliability. It lacks many of the features of modern GSE and would consume a great deal of space in the sled track blockhouse. The debugging of the test equipment software would also be difficult, and the availability of the NS-20 FTE is in doubt.

VI-A. HARDWARE

Before alternatives to the NS-20 FTE could be sought, the major GSE requirements had to be defined. These requirements and the GSE candidates are summarized in Table 2 and discussed below.

The Operational Support Equipment (OSE) option consists of the programmer group, coupler, power supplies and chiller from the standard launch facility. The launch control center function would be supplied by the Squadron Data Simulator (SDS). The SDS can copy software overlay modifications from a test site launch control center, thereby maintaining configuration with the current ground program. The primary advantage of this option is the low cost. A disadvantage is that the sled software would need to utilize a set of operational commands to respond and execute sled unique functions.

The Reentry System Launch Program (RSLP) equipment has capabilities similar to the OSE. However, items such as ground program overlays are embedded in firmware, and changes could be prohibitively costly. The cost of a new set is unknown at this time. Two sets of this equipment now exist at Vandenberg Air Force Base in California, and are scheduled for use in supporting RSLP test launches.

The Depot Support Equipment (DSE) and its emulator cannot communicate directly with the operational ground program. This option would be most advantageous if the objectives of the sled test were consistent with the use of the factory functional software in the MM III flight computer.

A recent candidate not shown on the matrix is the hardness surveillance system control unit (HSSCU) which is also based upon a very mature HP-1000 processor. This unit is now being evaluated as to its potential in supporting a sled test software program envisioned for the D-37.

The ability to load software and change the loaded software is a required feature of the test equipment. The ability to support direct memory addressing is also a desirable feature, but it is not a firm requirement if sufficient laboratory support for software troubleshooting exists at another site.

MS-20 SLED SUPPORT EQUIPMENT REQUIRED CAPABILITIES

	D-37 SLED S/N	GSE OPTIONS FOR THE STUDY			
		OSE W/SDS (NOTE)	RSLP (NOTE)	DSE (NOTE)	1800 EMULATOR (CCT)
POWER		X	X	X	X
COOLING		X	X	X	X
CONTROL	X	X	X	X	X
COMMUNICATION WITH D-37	X	X	X	X	X
MONITORING	X				
AUTO SAFING	X		X	X	X
SUPPORTABILITY		X	X		X**
MAINTAINABILITY		X	X		X**
BLOCKHOUSE FLOOR SPACE		X	X		X
FME INDICATOR	X				
FLIGHT INITIALIZATION DATA AND STATE VECTORS NEAR T=0 ON TELEMETRY	X				
ALIGNMENT DATA	X				
CALIBRATION DATA	X				
REENTER CAL FROM LAUNCH W/O POWER CYCLE	X				
MAINTENANCE STATUS	X				
UNINTERRUPTABLE POWER		?	?	?	?
SHORT TIMELINE CAL AND ALIGN	X				
SOFTWARE LOADING	X	X*	X*	X*	X*

TABLE 2. GSE REQUIREMENTS VERSUS CANDIDATE EQUIPMENT
PAGE 1 OF 2

NS-20 SLED SUPPORT EQUIPMENT REQUIRED CAPABILITIES

	D-37 SLED S/W	GSE OPTIONS FOR THE STUDY			
		OSE M/SDS (NOTE)	RSLP (NOTE)	DSE (NOTE)	1800 EMULATOR (CCT)
STRIP CHART DISPLAYS					
DATA RECORDING					
SPACE-TIME DATA ACQUISITION					
SLED ENVIRONMENTS DATA					
OPERATOR DISPLAY AND STATUS			X		X
PLACE GSP IN FREE INERTIAL TORQUE MODE FOR LAUNCH	X				
OUTPUT TELEMETRY AND DISCRETE DATA PRE AND POST LAUNCH	X				
OP CODE RESPONSES TO ACCOMMODATE OSE UP-LINK COMMANDS	X				
INHIBIT/ENABLE CONTINUOUS MONITORING	X				
MAINTAIN SA MODE	X				
SUPPORT S/W OVERLAYS		X	X		

NOTE-

THE INCLUSION OF THE THREE GENERAL SYSTEMS IS TO SHOW THE RELATIVE MERITS OF EACH AS RELATED TO THE TOPIC AND ONLY ONE APPROACH IS TO BE PURSUED.

* - BY ADDING A STANDARD CARTRIDGE TAPE UNIT (CTU)

** - COMPUTER CABLE TECHNOLOGY (CCT) NOT AVAILABLE

TABLE 2. GSE REQUIREMENTS VERSUS CANDIDATE EQUIPMENT
PAGE 2 OF 2

The test equipment must be supportable and easily maintainable by non-specialized contractor personnel and, upon occasion, test track personnel. Equipment which is not supported or not common has in the past presented problems. The equipment must afford the operator sufficient visibility and convenience for monitoring the test progress, the general health of the test article, and critical items of the test equipment. This visibility is normally in the form of computer-generated displays, printouts, strip charts and meters/readouts. A means of emergency power and cooling removal is also required. Most of the equipment considered to date and shown in Table 2 meet or can be easily adapted through the use of peripheral items to meet these requirements.

The conclusion to date regarding the selection of the GSE is that its cost will be highly sensitive to the type of sled test software used in the D-37. If the software chosen resembles the operational ground program, then the OSE or RSLP suites can be used without modifications. The remainder of the candidates would require software modification and would contain the attendant development costs.

VI-B. SLED SUPPORT EQUIPMENT

In addition to the GSE needed to support the guidance system for sled testing, there is a category of equipment needed for the test itself, referred to herein as sled support equipment (SSE). This includes equipment such as the sled forebody, the rockets, cooling systems, etc. A review was conducted by the Central Inertial Guidance Test Facility (CIGTF) personnel to identify and assess the effort required to provide SSE needed for NS-20 sled tests. Although this was a preliminary analysis, CIGTF experience with other guidance system sled test programs enabled them to identify with confidence the major items such as the forebody, the sled test instrumentation, the telemetry unit, miscellaneous ground equipment and the sled-borne coolant system.

The forebody would be a refurbished and modified unused asset from a previous program. This minimizes the cost and effort to provide this major element of SSE. The remaining SSE can be provided by modifying equipment used on other programs as well. CIGTF foresees no obstacles or major cost items in any of the SSE needed for the NS-20 sled tests.

The mechanical fixtures which attach and secure the test article would be chosen to simulate the vibration and attitude flight environments. These fixtures would also be designed to provide environmental protection, power, cooling, and data routing during the testing. Data would be telemetered during the sled test by a radio frequency link, and simultaneously recorded on board the sled vehicle.

VI-C. SOFTWARE

The NS-20 software should be representative of the software aboard an operational MM III missile. Of paramount importance is the capability to calibrate before and after the sled run without power interruptions. In addition, the achievement of the launch-ready status for the sled test should replicate that of the operational flight in order to avoid ambiguities in the results. These software operations should be identical in coding, and should reside on an identical NS-20 computer.

The sled launch mode for at least one run on each system should also replicate the missile flight mode in the torquing of the guidance instruments. Simulated flight navigation during the sled test allows the navigation data to be obtained in a position frame, thereby smoothing the raw accelerometer data.

There are also other features to be incorporated in the software in order to support the many different possible test objectives. For example, control of and communication with the guidance platform and the test support equipment should be provided. The platform and computer hardware should be monitored, and the self-test features of the software should be used to determine the overall health of the system and to avoid any potential damage. In response to a discrete issued by the sled test program, power and cooling must be automatically removed to prevent damage. This feature is commonly referred to as auto-safing and will sometimes involve monitoring the communications. A loss of communication is interpreted as failure of either the NS-20 or the GSE computer to service the communications link, and under certain conditions is cause to terminate power and cooling. An auto-safing summary of the critical events should be output in order to effect the application and removal of the power and cooling sources. An indication of the change from launch-ready to launch mode should be telemetered in order to assist the post-test analysis.

A software feature should be provided to allow rapid entry to launch mode. This will support simulated sled launches in order to practice activities which ensure launch team readiness. This so-called "short time line to launch" mode allows for practicing of normally lengthy sequences.

A method of re-entering calibration without power cycling should also be a feature of the test software. This feature will allow the assessment of any shifts of the instrument parameters across the sled launch without risking parameter shifts which frequently occur with power cycling.

The ability to position the platform in an arbitrary attitude is a candidate (unverified requirement) software feature. The

observability of platform errors may be enhanced by varying the platform orientation.

In order to avoid a potentially lengthy qualification of the now nonexistent sled software, a candidate software jump-off point involving an existing qualified software program should be determined. The first of these candidates is the current operational ground program. This software would yield the most realistic attainment of strategic alert. Memory in the flight computer required for the sled software changes can be made available by deleting the operational flight program. The second candidate for a jumping off point is the ground program previously used in the Fly-2 flight tests. The Fly-2 program had two NS-20 platform/D-37 computers aboard a single missile.

Other software candidates for the jumping off point are also under consideration, but appear to contain calibration and alignment perturbations as compared to the operational ground program. This would result in an extensive verification effort. One of these candidates is the vibration test software, which contains the option to return to calibration and alignment after the test without power cycling. Another candidate is the factory functional software which contains more extensive diagnostics than any derivative of the operational ground program. Upon identification of specific items or subsystems to be examined for degradation post-test, this software could be an integral part of achieving that objective. The pre and post-test execution of this software on a sled test unit does not necessarily have to occur at the sled test location, but could occur at either depot or factory sites.

VII. SUMMARY AND CONCLUSIONS

The status of a conceptual study of sled testing the Minuteman III Guidance System (NS-20) has been presented. Sled testing has proven to be of benefit to many ICBM guidance systems. Analytical findings show that sled testing will be of benefit to the NS-20 as well. It appears that the primary benefit of sled testing would be as a monitor to identify age-induced degradation, primarily in accuracy, but would also provide degradation information concerning functional performance and reliability. As a consequence, it is possible that problems could be detected as much as a year earlier with NS-20 sled tests and flight tests combined than with flight tests alone.

Three serious concerns which could prevent a worthwhile sled test program were addressed. Guidance system error observability was determined by a covariance analysis. It was shown that, with the exception of RV deployment error, the major error terms affecting the guidance system CEP are observable in sled test

(although some error terms have to increase to three times their error budget values).

An area which is under investigation that may enhance error term observability during sled testing is to include different NS-20 orientations.

It was mentioned that functional performance could be monitored in sled tests by reviewing functional signals for aberrant behavior. Reliability monitoring could be achieved by analyzing guidance system failures which occur during the test. In this way, sled tests would augment the NS-20 flight test program, which is currently limited to three flights per year. Sled tests would thus double the sample size of guidance system tests in a dynamic environment (combining acceleration and vibration).

The advantages and disadvantages of sled testing as compared to other test methods were discussed. It was seen that sled testing is unique, because it is the ground test which is most like a flight test. It is much less expensive, however, than flight testing. Finally, the hardware and software requirements for an NS-20 sled test program were presented.

VIII. ACKNOWLEDGEMENTS

This work has been performed in support of LTC Stu Flood, Guidance PMT Chief of the Sustainment Support Organization of the Air Force Systems Command, under contract number F04704-92-C-0005. The authors would like to thank the following personnel for their useful technical support during the course of this work: Captain Curtis Coffman and Bob Lawrence of the 46th Test Group; Gerry Grimaldi and Tom Williams of Rockwell International; and Gene Hymas, Bruce Brown, Benjamin Frint, Bob Jezik, Nick Kfoury, Dave Larson, Richard Holdeman, and Ken Kosaka of TRW.

IX. REFERENCES

[Aiyawar] R. Aiyawar, R. Boylan, and E. Graves, "AIRS/Sled Test Sensitivity Analysis Report," Cambridge, MA: The Charles Stark Draper Laboratory, June 1977.

[Bunce] K. Bunce and G. Grachis, "Utilization of Velocity Residual Signatures to Determine Error Terms of Inertial Components and Systems in a Sled Test Environment," Fourteenth Biennial Guidance Test Symposium, pp. 349-385, October 1989.

[Burnett] R. Burnett and R. Macary, "Design of Precision Vibration Test Station for High Accuracy Accelerometer Calibration,"

Fifteenth Biennial Guidance Test Symposium, pp. 259-270, September 1991.

[Cuevas] J. Cuevas "The History of AIRS Rocket Sled Testing MPMS Through Peacekeeper", 21st Joint Services Data Exchange for Guidance, Navigation and Control Symposium, October 1992.

[Gelb] A. Gelb (editor), Applied Optimal Estimation, Cambridge, MA: The MIT Press, 1974.

[Hand] J. Hand and A. Harris, "Development of Stellar Tracking Requirements for Rocket Sled Testing of Advanced Inertial Measurement System", 21st Joint Services Data Exchange for Guidance, Navigation and Control Symposium, October 1992.

[McAllister] D. McAllister and J. Wilcox, "Digital Computer Program for Generalized Inertial Guidance System Error Analysis," Redondo Beach, CA: TRW Systems Group, March 1969.

[Nielsen] R. Nielsen, B. Cosentino, R. Lawrence, and S. Doyle, "Reverse Velocity Sled Test Simulations to Determine Uncertainties in Accelerometer Model Coefficients," Fourteenth Biennial Guidance Test Symposium, pp. 427-477, October 1989.

[Peters1] R. Peters and S. Foote, "Determination of Nonlinear Coefficients in a Dry Accelerometer by Vibration Testing," Fifteenth Biennial Guidance Test Symposium, pp. 237-258, September 1991.

[Peters2] R. Peters and R. Marquess, "A Practical Three Axis Balancing System for Precision Centrifuge Applications," Fifteenth Biennial Guidance Test Symposium, pp. 225-235, September 1991.

[Rockwell] Minuteman III G & C Error Model Update, Rockwell International, Anaheim, CA, November 21, 1989.

SPACE-TIME SYSTEM

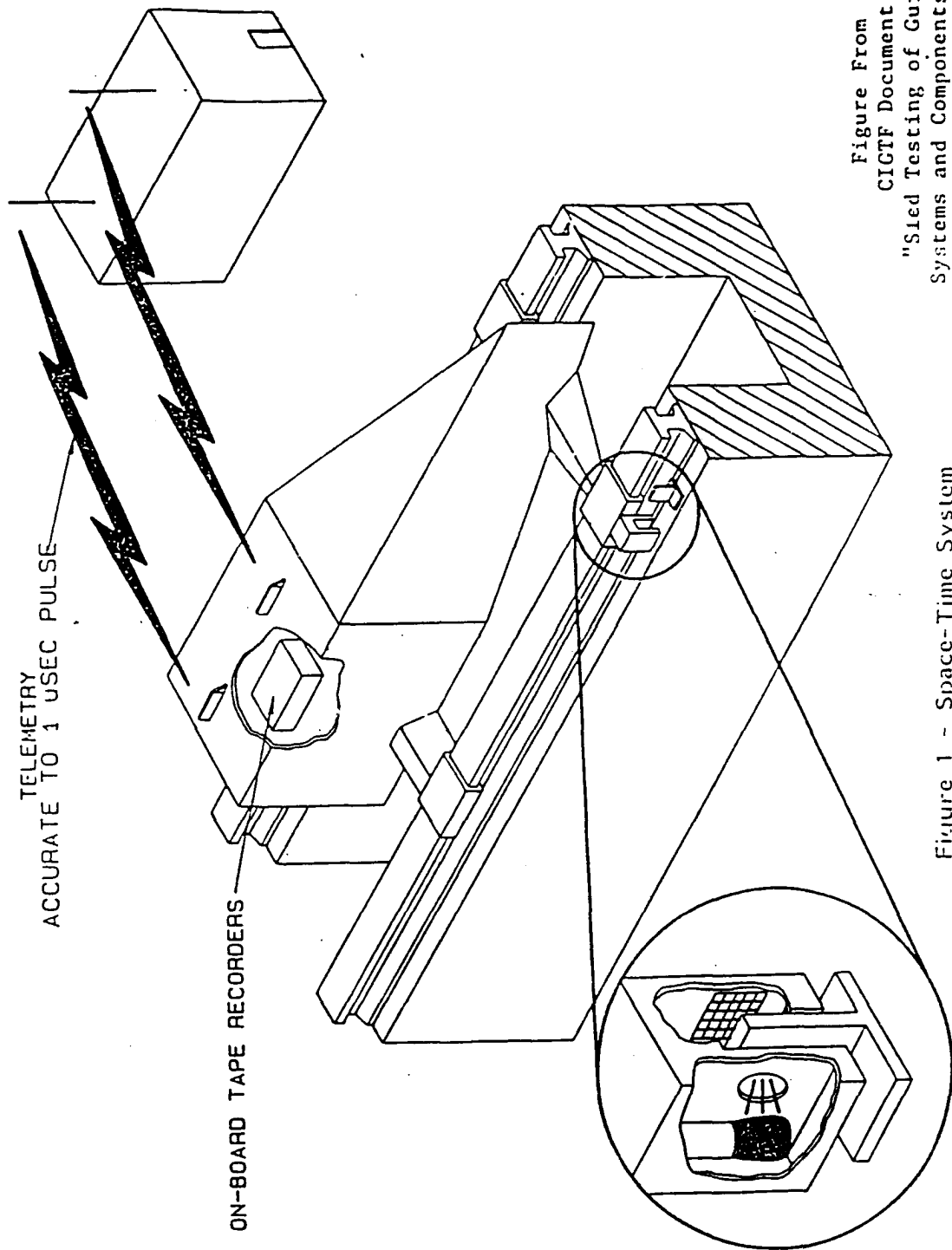

Figure 1 - Space-Time System

Figure From
CICTF Document
"Sied Testing of Guidance
Systems and Components" 1987

TRACKSITE CONFIGURATION

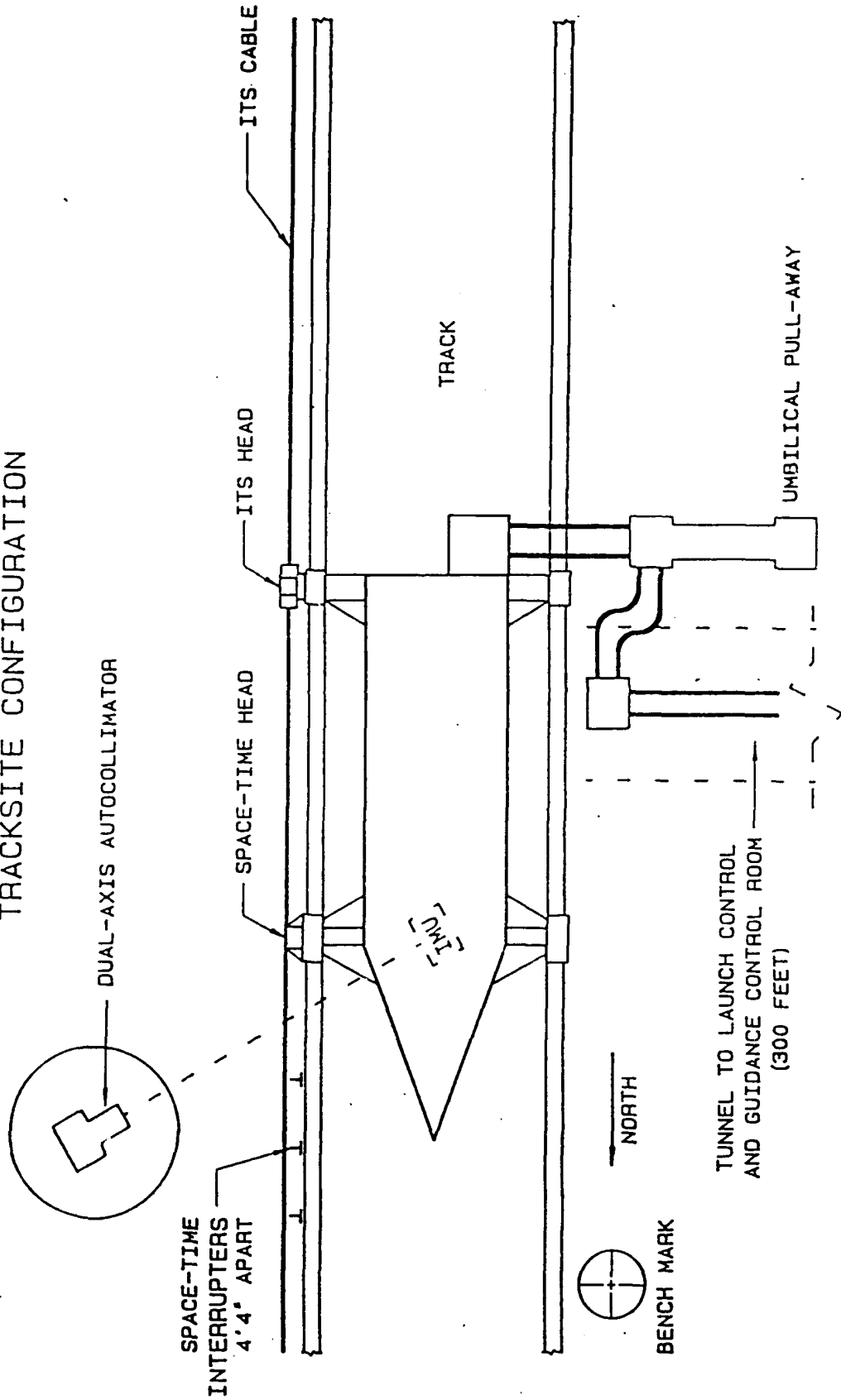

Figure From
CIGTF Document
"Sled Testing of Guidance
Systems and Components" 1987

Figure 2 - Tracksite Configuration.

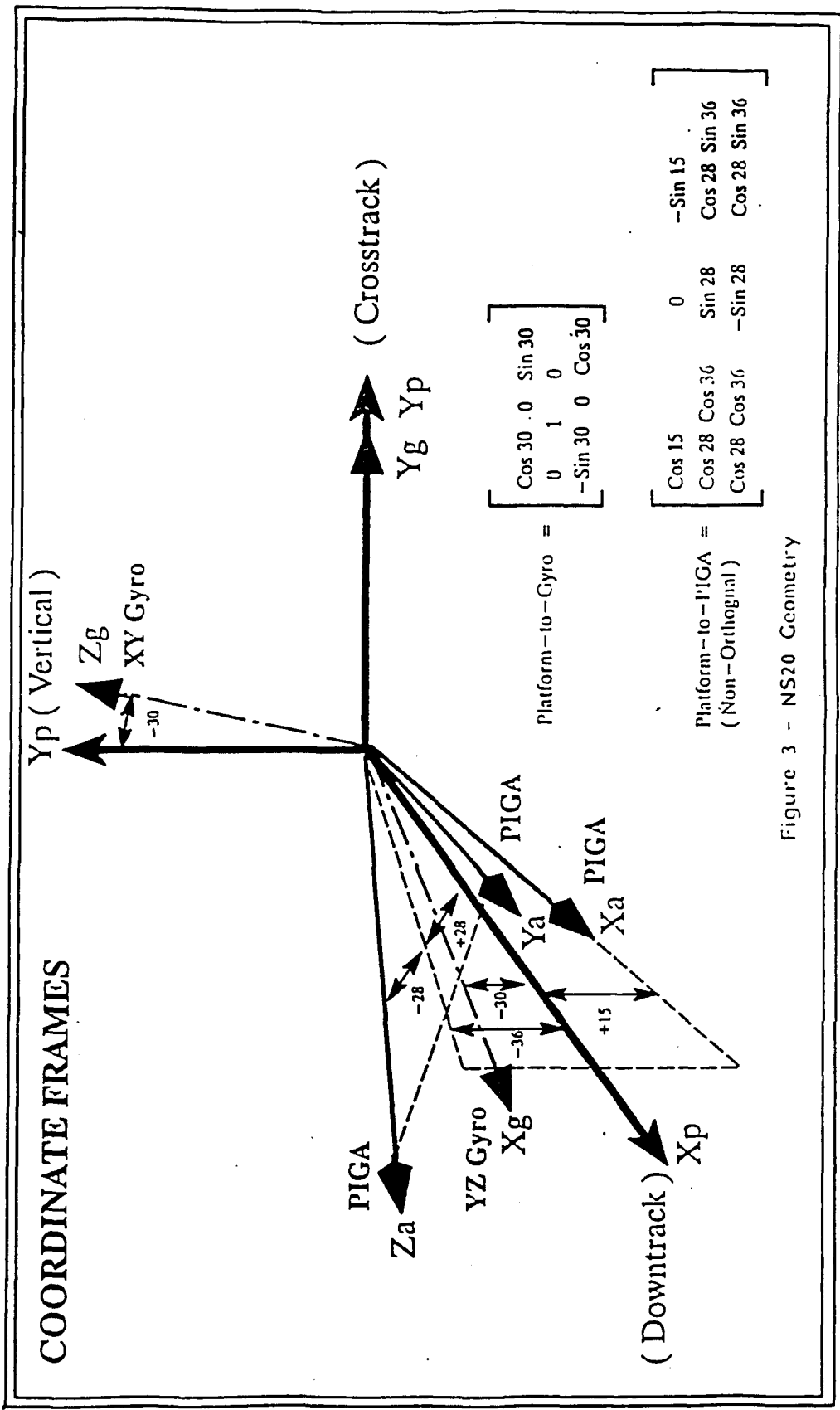

Figure 3 - NS20 Geometry

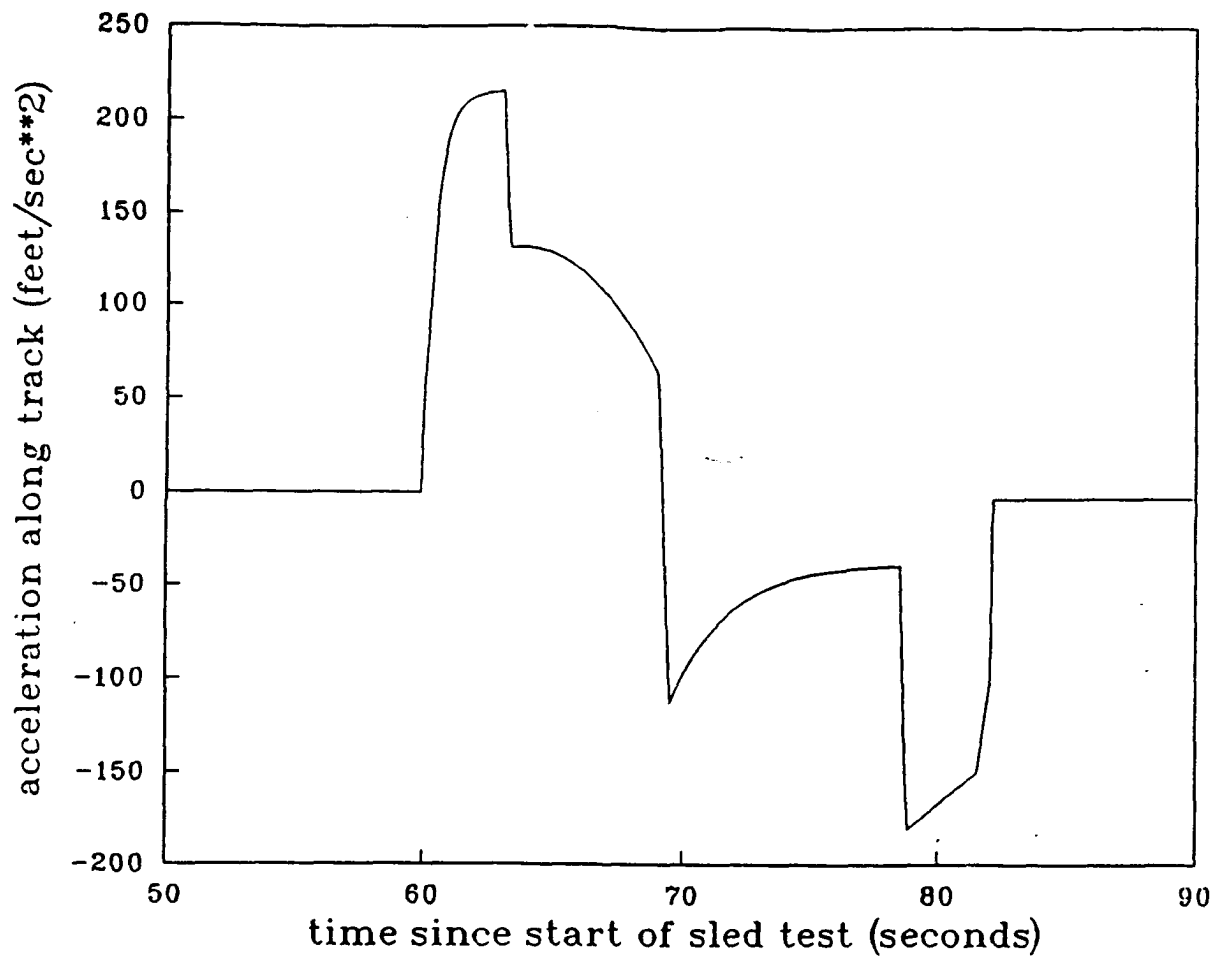

Figure 4 - Sled Test Acceleration Profile