

# Real Time Voice Transmission over Wireless medium using GNU Radio and USRP

EEC 687 Mobile Computing  
Final Project Presentation

By  
Darshana Shah  
Electrical & Computer Engineering  
Cleveland State University, Ohio  
Email: d.shah44@csuohio.edu  
05/06/2009

1

## Outline

- Introduction
- Background of the project
- Project Goal and Block Diagram
- Experimental setup
- Results
- References
- Question Time

2

## Introduction

- › SDR (Software Defined Radio) implements everything in software. E.g. filters, amplifiers, encoder/decoder, modulator/demodulator.
- › Free SDR tool kit is available i.e. GNU Radio. So cheap compared to hardware.
- › Debugging is easy compared to hardware.
- › Can transmit large data or voice files using hardware. E.g. USRP.
- I use GNU Radio as software environment and USRP as hardware platform.

3

## Background of the Project GNU Radio

- › Free Software defined radio tool.
- › Need to purchase license but it is available online and it is free.
- › It can work in Linux as well as Windows operating system.
- › GNU Radio provides a library of signal processing blocks and the glue to connect it all together.
- › It uses C classes to implement different signal processing functions and python for main application programming. Swig converts C classes to Python compatible classes. Swig is a tool that enables python code to call C++ code.
- Running on hardware platform called USRP.

4

# Background of the Project

## USRP (Universal Software Radio Peripheral)

- Covers wide range of frequency compared to inbuilt sound card (up to KHz). One USRP has one mother board and it can support up to four daughter boards which can cover frequency from analog to some GHz.
- Compatible with GNU Radio.
- Entire design is open source.
- No software or license needed to be purchased.
- USRP has FPGA, DAC and RF front end at transmitter side and RF front end, ADC and FPGA at receiver side which is shown in next block diagram.

5

## USRP Hardware and General Block Diagram

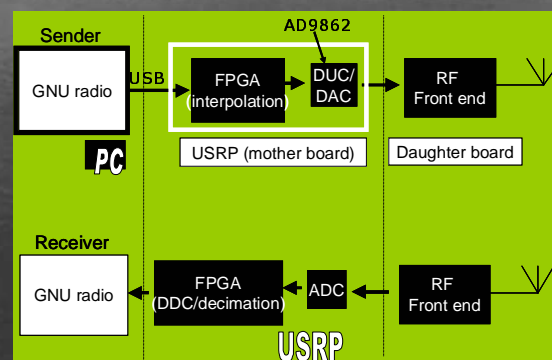
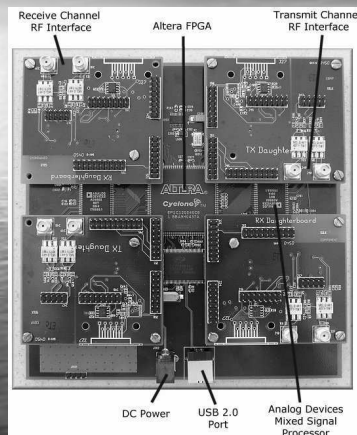

6

# Project Goal

- To transmit real time voice from one place to another over wireless medium. Means speak in microphone attached with one pc and hear it from speaker connected to other pc over wireless medium.
- I use gnu radio software to encode and modulate voice at transmitter side and to decode and demodulate voice at receiver side.
- I use one USRP at transmitter side and one USRP at receiver side to transmit and receive voice.
- I use rx\_voice.py and tx\_voice.py python scripts from gnu radio examples.

7

# Block Diagram

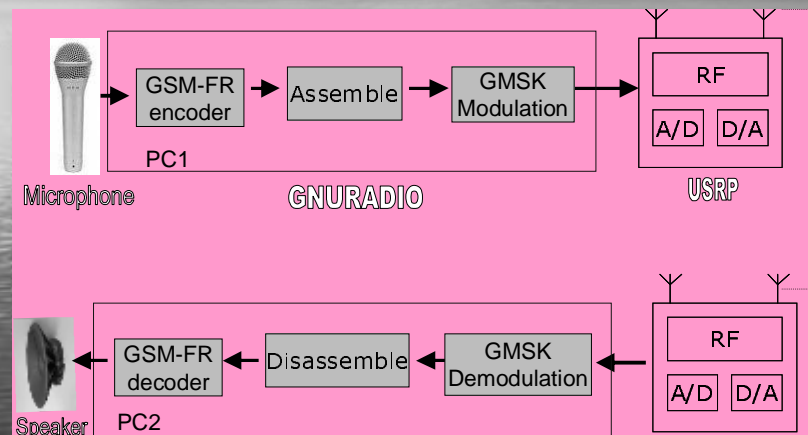

8

## GSMR Encoder/Decoder

- GSM FR was the first digital speech-coding standard which was used in GSM digital mobile phone system.
- Encoder
  - It is used to encode real time voice
- Decoder
  - It is used to decode real time voice

9

## What is GMSK modulation

- Signal is applied to Gaussian filter before applying to modulator.
- It has high spectral efficiency compared to QPSK. Number of bits/second is high. Consumes more power.
- Reduces side band power so reduced out-of band interference.

10

## Experimental Setup



## Past Work

- I run different audio files and usrp files from GNU Radio examples and it works fine.
- I receive data from one PC to other over wireless medium correctly. Means data communication between two USRP works fine. For that I used `benchmark_tx.py` and `benchmark_rx.py`.
- I modified this code to transmit my data file instead of default and it works fine.
- I tried to transfer voice. But it was not working. I always got false packets and sometimes did not receive anything.

12

## Results

- I can transmit my real time voice over wireless medium.
- I tried to play internet radio on one pc and I can hear it from other pc.

13

## Advantages

- If we have only one Ethernet card.
- Transmission over wireless medium using router needs file sharing. That is security hole. If you want to access file system without file sharing we need to buy software which is very costly. Using USRP there is no security hole. No file sharing is needed.
- We can program FPGA in usrp according to our requirement but can not program router accept some parameter setting.

14

## References

- <http://www.gnuradio.org/trac>
- <http://www.ettus.com/>
- <http://www.gnu.org/software/gnuradio/doc/exploring-gnuradio.html>
- Dr. Chansu.Yu Week 05 lecture notes. It is available at, [http://academic.csuohio.edu/yuc/mobile09/09\\_lab04\\_Week05\\_usrp\\_ipaq.pdf](http://academic.csuohio.edu/yuc/mobile09/09_lab04_Week05_usrp_ipaq.pdf)
- [http://en.wikipedia.org/wiki/GMSK#Gaussian\\_minimum-shift\\_keying](http://en.wikipedia.org/wiki/GMSK#Gaussian_minimum-shift_keying)
- [http://users.ecel.ufl.edu/~zhifeng/project/GNU\\_Radio\\_U\\_SRP/index.htm](http://users.ecel.ufl.edu/~zhifeng/project/GNU_Radio_U_SRP/index.htm)

15

## Thank You !!!

- Questions?

16